

APS023 Part 1 Transmit Power Calibration and Management

Version 1.3

**This document is subject to change without
notice**

TABLE OF CONTENTS

1 INTRODUCTION.....4

1.1 OVERVIEW 4

1.2 WHAT DO WE MEAN BY TRANSMIT POWER?..... 4

1.3 THE IMPORTANCE OF TRANSMIT POWER TO LINK BUDGET..... 5

1.4 THE DW1000 FRAME STRUCTURE..... 5

2 HOW TRANSMIT POWER IS MEASURED FOR REGULATORY COMPLIANCE.....6

2.1 OVERVIEW 6

2.2 RADIATED MEASUREMENTS..... 6

2.3 MEASUREMENT WINDOW 6

2.4 MEASURING MEAN POWER..... 7

2.5 MEASURING PEAK POWER 7

3 OPTIMIZING TRANSMIT POWER FOR SHORT FRAMES.....8

3.1 INTRODUCTION 8

3.2 THE BASIC PRINCIPLE 8

4 ADJUSTING & CALIBRATING TRANSMIT POWER IN THE DW1000.....11

4.1 INTRODUCTION 11

4.2 THE IMPORTANCE OF CALIBRATING THE TRANSMIT POWER 11

4.3 TRANSMITTER MODES OF OPERATION 11

4.4 ADJUSTING TRANSMIT POWER IN THE DW1000 11

5 MANUAL MODE13

5.1 INTRODUCTION 13

5.2 ADJUSTING TRANSMIT POWER IN MANUAL MODE..... 13

5.3 CALIBRATING TRANSMIT POWER IN MANUAL MODE 15

5.3.1 *Introduction* 15

5.3.2 *Frames always longer than one millisecond*..... 16

5.3.3 *More than 1 frame transmitted per millisecond*..... 16

5.3.4 *Only one frame transmitted per millisecond and frame duration constant* 16

5.3.5 *Only one frame transmitted per millisecond but with variable duration*..... 16

5.4 ENABLING MANUAL MODE..... 16

6 SMARTTX POWER MODE17

6.1 INTRODUCTION 17

6.2 ADJUSTING TRANSMIT POWER IN SMARTTX POWER MODE 17

6.3 CALIBRATING TRANSMIT POWER IN SMARTTX POWER MODE 19

6.4 ENABLING SMARTTX POWER MODE..... 19

7 CALIBRATING A DW1000 TRANSMITTER WITH BOOST20

8 MANAGING TRANSMIT POWER DURING NORMAL OPERATION.....23

8.1 INTRODUCTION 23

8.2 VARIATION OF TRANSMIT POWER WITH TEMPERATURE AND VOLTAGE 23

8.3 MAINTAINING TRANSMIT POWER OVER TEMPERATURE AND VOLTAGE 23

8.3.1 *Is it necessary?*..... 23

8.3.2 *How do I implement it?*..... 24

9 REFERENCES27

9.1 LISTING..... 27

10 DOCUMENT HISTORY27

10.1 REVISION HISTORY 27

11	MAJOR CHANGES	27
12	FURTHER INFORMATION	29
13	APPENDIX 1: IS IT NECESSARY TO MEASURE PEAK POWER IN PRODUCTION?	30

LIST OF TABLES

TABLE 1: TYPICAL USE CASE EXAMPLES	24
TABLE 2: APPROXIMATE RATES OF CHANGE OF TX POWER WITH TEMPERATURE AND VOLTAGE	24
TABLE 3: TABLE OF REFERENCES	27
TABLE 4: DOCUMENT HISTORY.....	27

LIST OF FIGURES

FIGURE 1: TRANSMIT POWER AT VARIOUS DIFFERENT POINTS IN THE SIGNAL PATH	4
FIGURE 2: DW1000 FRAME STRUCTURE	5
FIGURE 3: REGULATORY TRANSMIT POWER MEASUREMENT WINDOW – LONG FRAMES.....	6
FIGURE 4: REGULATORY TRANSMIT POWER MEASUREMENT WINDOW – SHORT FRAMES	6
FIGURE 5: FRAME DURATION LESS THAN MEASUREMENT WINDOW.....	8
FIGURE 6: OPERATION OF THE PRINCIPLE.....	8
FIGURE 7: CALIBRATION WITH FRAMES SHORTER THAN 1 MS.....	9
FIGURE 8: RELATIONSHIP BETWEEN FRAME DURATION AND ADDITIONAL TRANSMIT POWER.....	10
FIGURE 9: TRANSMITTER POWER CONTROL REGISTER.....	11
FIGURE 10: STRUCTURE OF THE 8-BIT TRANSMIT POWER CONTROL BYTE	12
FIGURE 11: TRANSMIT POWER CONTROL REGISTER IN MANUAL MODE OF OPERATION	13
FIGURE 12: TIME DOMAIN PLOT OF FRAME SHOWING INCREASED POWER IN PREAMBLE AND PAYLOAD PORTIONS OF THE FRAME.....	14
FIGURE 13: DECISION TREE FOR TRANSMIT POWER CALIBRATION IN MANUAL MODE	15
FIGURE 14: THE FOUR FRAME-DURATION “BINS”.....	17
FIGURE 15: TRANSMIT POWER CONTROL REGISTER FOR FRAMES WITH DURATION > 500µs.....	18
FIGURE 16: TRANSMIT POWER CONTROL REGISTER FOR FRAMES WITH DURATION BETWEEN 250 µs & 500 µs	18
FIGURE 17: TRANSMIT POWER CONTROL REGISTER FOR FRAMES WITH DURATION BETWEEN 125 µs & 250 µs	18
FIGURE 18: TRANSMIT POWER CONTROL REGISTER FOR FRAMES WITH DURATION LESS THAN 125 µs	19
FIGURE 19: SPECTRUM OF CORRECTLY CALIBRATED TRANSMITTER AT DATA RATE OF 6.8 Mb/s WITH PRF16 AND NO BOOST APPLIED	20
FIGURE 20: TRANSMITTING ONE FRAME PER MILLISECOND	21
FIGURE 21: SPECTRUM OF CORRECTLY CALIBRATED TRANSMITTER AT 6.8 Mb/s DATA RATE WITH PRF16 AND 7 dB BOOST APPLIED.....	21
FIGURE 22: VARIATION OF TRANSMIT POWER OVER VOLTAGE AND TEMPERATURE.....	23
FIGURE 23: TRANSMIT POWER COMPENSATION SCHEME OVER TEMPERATURE & VOLTAGE.....	26
FIGURE 24: EXAMPLE OF PEAK POWER MARGIN WHEN PHR MEAN LIMIT SET TO -41.3 DBM / MHZ.....	30

1 INTRODUCTION

1.1 Overview

This application note deals with the whole area of the power of the RF signal transmitted by the DW1000 / DWM1000: -

- What does it mean?
- Why is it important?
- How to calibrate it
- How to measure it
- How to use DW1000 features such as SMARTTX POWER to optimize it

1.2 What do we mean by transmit power?

It is important that we understand and define “transmit power” before we go any further.

Transmit power is generally used to refer to the signal power radiated from an antenna into the surrounding environment. It can also refer to the signal power output from the DW1000 or at any point in the chain between the DW1000 and the product’s antenna.

You should pay particular attention to the definition of transmit power in data sheets / manuals / test specifications so that you understand exactly what is being referred to.

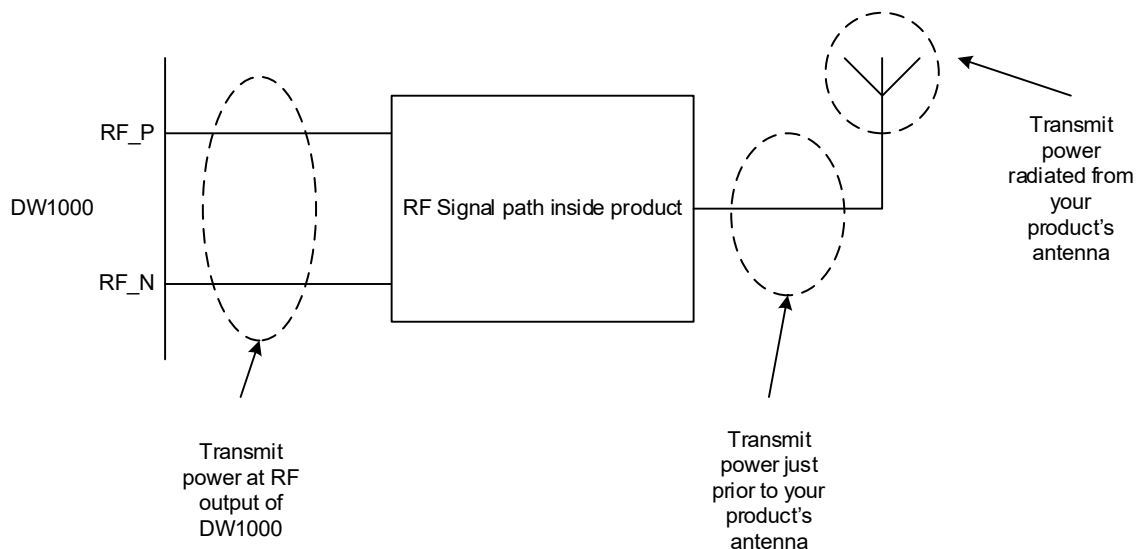

Figure 1: Transmit power at various different points in the signal path

Transmit power is generally measured in dBm; i.e. power expressed in dB relative to 1 mW. The bandwidth over which the power is measured is very important, so measurements are often quoted as dBm / x MHz where x defines the bandwidth over which the power is measured.

For example, an ideal signal transmitted at -41.3 dBm / MHz into a 500 MHz wide channel is equivalent to -14.3 dBm / 500 MHz. You should pay careful attention to the measurement bandwidth to understand exactly what is being referred to.

This note uses the terms transmit power and transmitted power interchangeably throughout and generally refers to signal power transmitted from a product’s antenna unless otherwise stated.

1.3 The importance of transmit power to link budget

The signal power that arrives at a receiver depends on a number of factors as seen by examining Friis' path loss formula: -

$$P_R [dBm] = P_T [dBm] + G [dB] - L [dB] - 20 \log_{10}(4\pi f_c d / c)$$

Where: -

- P_R is the received signal power;
- P_T is the transmitted power from the DW1000 (note the definition here)
- G includes the antenna gains of the transmitting and receiving antennas, as well as any other gain from external amplifiers.
- L includes any PCB, cable, connector and other losses in the system
- c is the speed of light, 299792458 m/s;
- f_c is the center frequency of the channel used, expressed in Hertz;
- d is the distance in meters between the transmitter and receiver.

Provided P_R is greater than the receiver sensitivity, the receiver will receive the signal correctly.

So, the power of the received signal level directly relates to the transmitted power. For each additional dB of power transmitted by the DW1000 the power of the received signal increases by that same amount.

1.4 The DW1000 frame structure

Before discussing transmit power any further we need to turn our attention to the DW1000 frame structure illustrated in Figure 2 below.

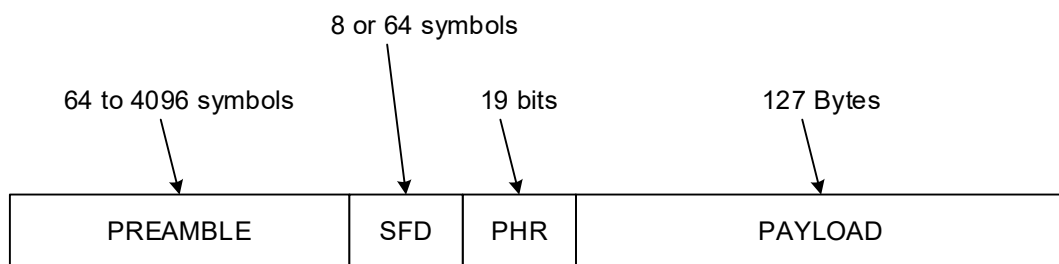

Figure 2: DW1000 frame structure

[1] and [2] give further details but, in summary, each frame consists of three distinct parts: -

- The preamble followed by the start of frame delimiter (SFD) indicating the end of the preamble sequence
- The PHY header (PHR)
- The payload or data portion

For the purposes of transmit power adjustment and calibration it is not necessary to know the detailed functionality of each of these components. It is important to know that the modulation scheme applied to the PHR is different to that applied to the Preamble / SFD and the payload portions of the frame.

The different modulation schemes used in the different parts of the frame have different peak to average transmit power ratios. The PHR has a higher peak to average transmit power ratio than the other two regions of the frame. This means that the mean transmit power setting of the PHR has the most significant impact on the peak transmit power of the frame. This has important implications when we are calibrating the transmit power and in particular when we come to exploit certain characteristics of the power measurement process to allow us increase transmit power in certain situations.

2 HOW TRANSMIT POWER IS MEASURED FOR REGULATORY COMPLIANCE

2.1 Overview

Ultra-wideband regulations (see [4] and [5] for examples) generally define a maximum limit for mean transmit power as -41.3 dBm / MHz and a maximum peak power limit of 0 dBm / 50 MHz. You should carefully consider the regulatory requirements in the regions in which you intend to sell your products to be sure your products meet the required transmit power limits and other regulatory requirements.

2.2 Radiated measurements

UWB transmit power measurements are radiated measurements; it is the power that your product is radiating (intentionally via its antenna and unintentionally via other means) that regulatory authorities are interested in measuring.

The UWB regulations referred to above and in [4] & [5] define the transmit power measurement limits and the methods for making those measurements.

There are other standards relating to conducted emissions. These apply to all products with any kind of cable connection (power cord, interface cables etc.), are not exclusive to UWB products and we are not considering them here.

2.3 Measurement window

Regulatory authorities generally measure UWB transmit power over a one millisecond interval irrespective of the frame duration. See Figure 3 & Figure 4 below.

For regulatory purposes, transmit power is measured over this duration irrespective of the frame duration

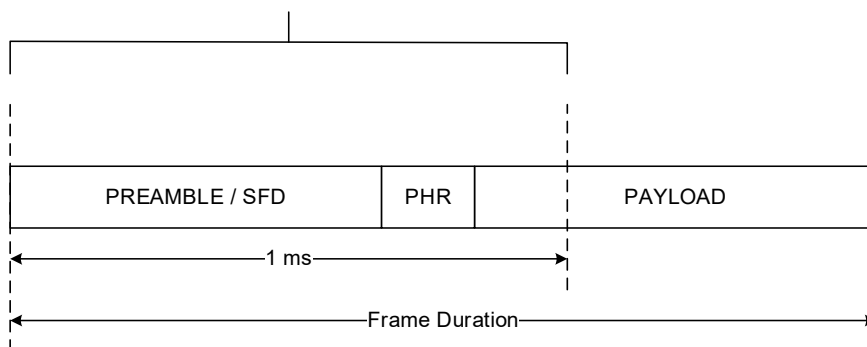

Figure 3: Regulatory transmit power measurement window – long frames

For regulatory purposes, transmit power is measured over this duration irrespective of the frame duration

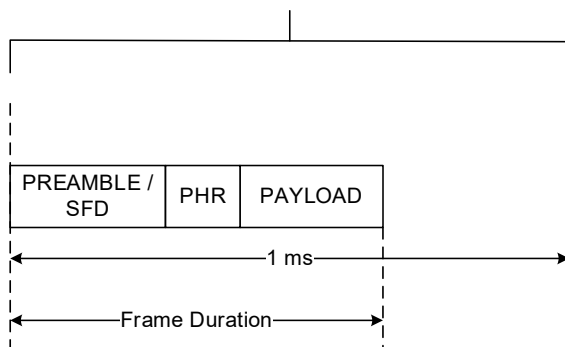

Figure 4: Regulatory transmit power measurement window – short frames

2.4 Measuring mean power

The regulatory authority in each jurisdiction specifies the method for measuring mean transmit power. For typical examples, refer to [4] & [5]. Decawave application note APS012 describes this method.

2.5 Measuring peak power

The regulatory authority in each jurisdiction specifies the method for measuring peak transmit power. For typical examples, refer to [4] & [5]. Decawave application note APS012 describes this method.

You should take care to use a spectrum analyser with a resolution bandwidth (RBW) of 50 MHz when measuring peak power. A lower bandwidth machine, even if the compensation formula given in some of the regulatory standards is used, will give an incorrect result and your system will fail. This is not an issue with your system – it is an issue with the measurement scheme. The problem does not arise if a 50 MHz RBW spectrum analyser is used.

3 OPTIMIZING TRANSMIT POWER FOR SHORT FRAMES

3.1 Introduction

Section 2 described the method by which UWB transmit power is measured from a regulatory compliance perspective using a sampling window of 1 ms. This section describes how the DW1000 makes use of that measurement method to allow additional transmit power in certain circumstances.

3.2 The basic principle

The basic principle is that for frame durations less than 1 ms, the transmit power of certain portions of the frame can be increased by an amount that depends on the duration of the frame relative to 1 ms.

When this increased power is measured over the full 1 ms sampling window, the measured power is less than the actually transmitted power measured over the duration of the frame.

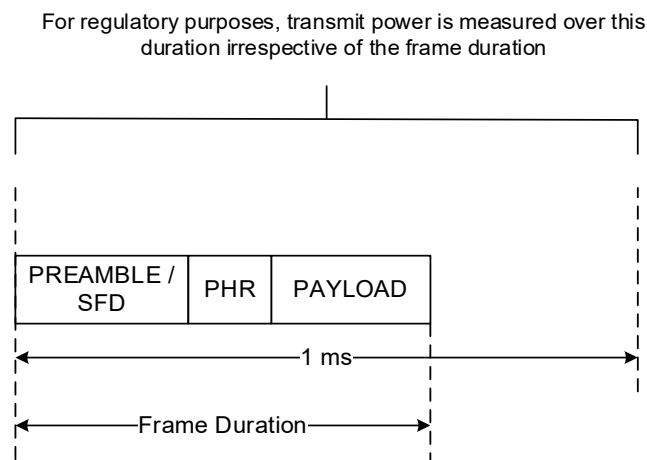
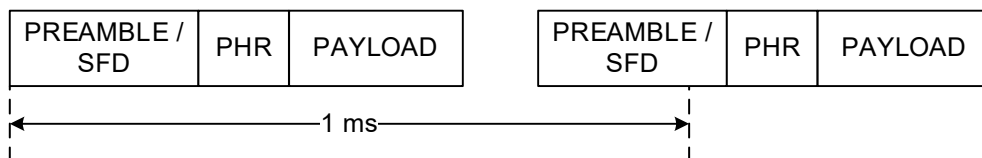

Figure 5: Frame duration less than measurement window

Provided **only one** frame is transmitted per millisecond then this principle can be applied as illustrated in Figure 6 below.



Boost **can** be applied in this scenario



Boost **cannot** be applied in this scenario

Figure 6: Operation of the principle

When correctly calibrated as described in sections 5.37 and measured as per section 2.4 the measured transmit power appears the same as if no boost had been applied when in fact, it has, and significant link budget benefit can be obtained as a result.

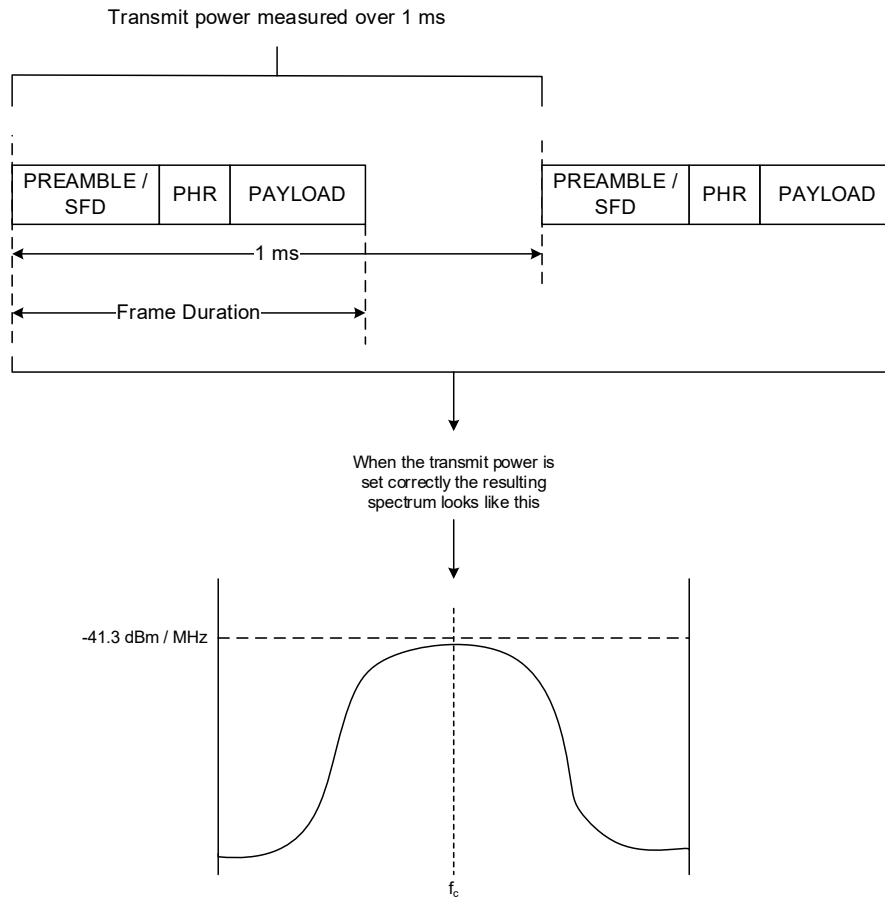

Figure 7: Calibration with frames shorter than 1 ms

The relationship between the frame duration and the additional power that may be transmitted may be calculated as follows: -

$$Power\ Boost(dB) = 10 \log_{10} \frac{1000 \mu s}{actual\ frame\ duration\ (\mu s)}$$

and is as shown in Figure 8.

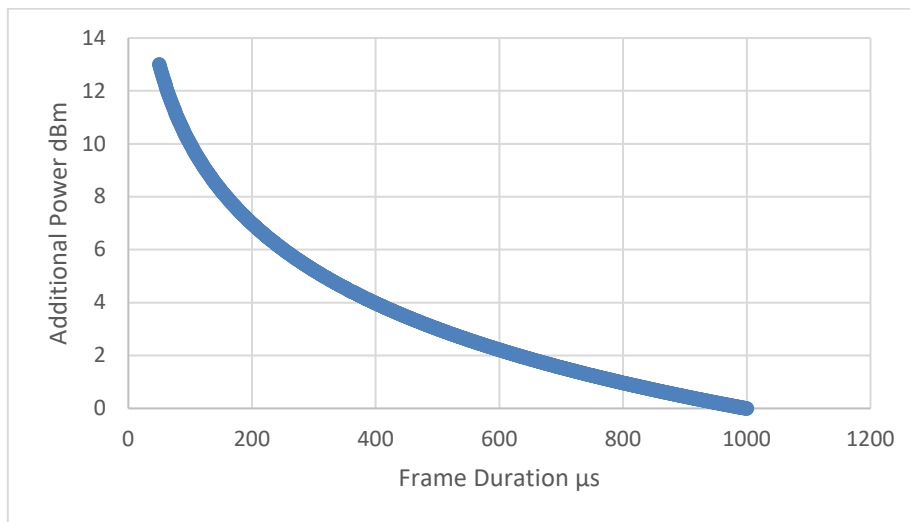

Figure 8: Relationship between frame duration and additional transmit power

The duration of a frame in an exchange between two DW1000 nodes depends on a number of factors particularly the chosen preamble length, the selected data rate and the number of bytes in the payload. Refer to [1] for more information.

Making use of this principle is explored in detail in sections 5, 6 and 7 of this note.

4 ADJUSTING & CALIBRATING TRANSMIT POWER IN THE DW1000

4.1 Introduction

This section deals with the need to calibrate transmit power and the methods of doing so in the DW1000 (and DWM1000).

4.2 The importance of calibrating the transmit power

Section 1.3 discussed the importance of transmit power in the context of link budget and the fact that the power arriving at the receiver is directly related to the power transmitted by the transmitter. Given that the transmit power regulatory limit in most UWB systems is low (-41.3 dBm / MHz) it is very important that each transmitter transmits as close to the limit as possible to achieve maximum link budget.

There are slight variations in transmit power between one DW1000 device and another at nominal temperature and voltage for the same transmit power setting. Over a large number of devices, this spread is approximately 2 dB.

If you decide not to calibrate each DW1000 transmitter individually then you will need to “back-off” the transmit power level setting in the DW1000 to ensure that even at the highest-power end of the spread the transmit power cannot exceed the regulatory limit. This will lead to some transmitters being 2 – 3 dB below the limit with a corresponding impact on link budget and a significant variation in the performance of your system.

Decawave recommends that you calibrate each transmitter’s mean power individually during your product production process.

4.3 Transmitter modes of operation

The DW1000 supports two different modes of transmitter operation: -

1. The transmit power is set manually for each transmitted frame – we call this **MANUAL mode**
2. The transmit power is automatically chosen from one of four pre-programmed values depending on the duration of the frame – we call this **SMARTTX POWER mode**

Each of these will be discussed in separate sections below but before doing that we need to consider how transmit power is adjusted in general. We can then apply this to the two modes of operation.

4.4 Adjusting transmit power in the DW1000

Transmit power in the DW1000 is adjusted using a 32 bit register at address 0x1E offset 0 in the DW1000 register map. This register is divided into four 8-bit bytes each of which contains a transmit power setting.

Depending on the selected transmitter mode of operation, the use of these four bytes is different.

3	3	2	2	2	2	2	2	2	2	2	1	1	1	1	1	1	1	1	0	0	0	0	0	0	0	0	0	0	0	0	
1	0	9	8	7	6	5	4	3	2	1	0	9	8	7	6	5	4	3	2	1	0	9	8	7	6	5	4	3	2	1	0
BYTE 3								BYTE 2								BYTE 1								BYTE 0							
0x0E								0x08								0x02								0x22							

Figure 9: Transmitter power control register

Register 0x1E has a pre-set default value as shown in Figure 9 (0x0E080222). In each of the two transmitter modes this default value will result in a different transmit output power. It is important that you calibrate the transmit output power in your desired mode of operation and that you adjust this

default value to ensure the transmitted output power meets regulatory requirements.

There is an area reserved in the DW1000's OTP memory for storing these calibrated values. These values can be programmed into OTP at time of product calibration, and then subsequently read out by the host controller and used to program register 0x1E during chip start-up.

As with other registers in the DW1000, the content of register 0x1E is retained in non-volatile memory while the DW1000 is in its SLEEP or DEEPSLEEP state so you do not have to reprogram it when the device comes out of either sleep state.

In both modes of operation, each of the 8-bit bytes in the register has the same structure as outlined in Figure 10 below. The most significant 3 bits control the operation of the Driver Amplifier (DA) just prior to the DW1000 RF output. The five least significant bits control the gain of the mixer in the transmit strip in which the baseband pulse train is mixed up to the carrier frequency for the selected channel.

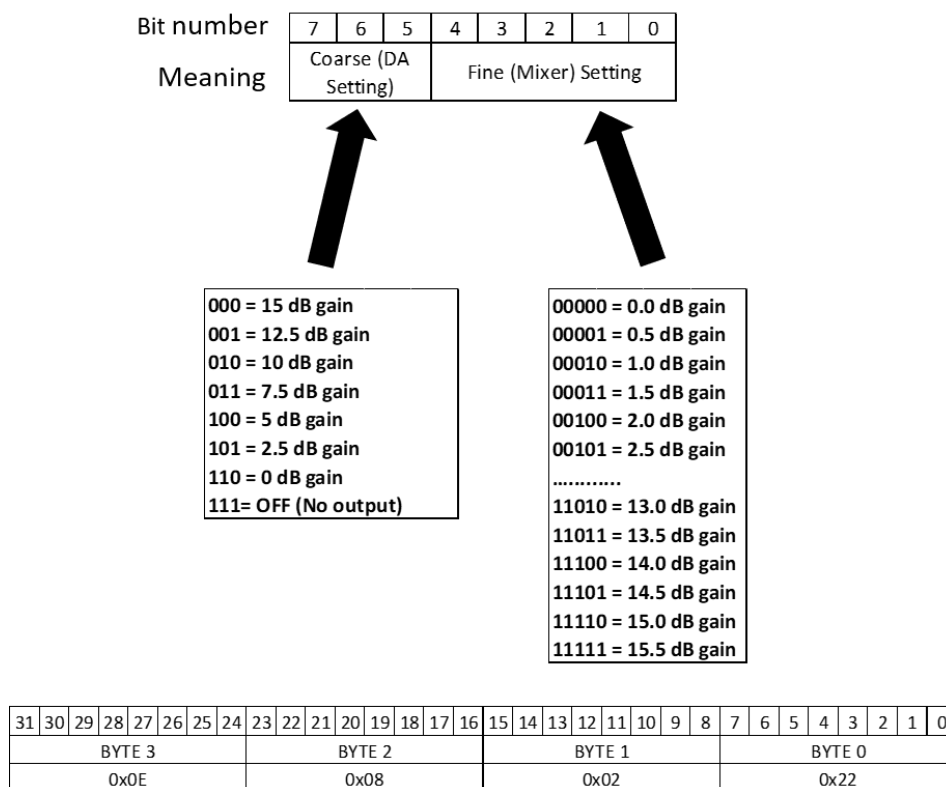

Figure 10: Structure of the 8-bit transmit power control byte

This gives a gain control range of 30.5 dB in 0.5 dB steps.

For best performance the DA should be adjusted first so that the transmit power is close to the desired level and then the mixer gain should be adjusted to achieve the required value.

5 MANUAL MODE

5.1 Introduction

In MANUAL MODE, a single transmit power setting is applied to all transmitted frames. Within that single power setting, the DW1000 allows independent control over the power of a) the PHR portion of the frame and b) the Preamble & Payload portions of the frame.

5.2 Adjusting transmit power in MANUAL mode

Because one power setting is required for the PHR portion of the frame and another for the preamble and data portions of the frame this means that two bytes out of the four in register 0x1E are used as follows: -

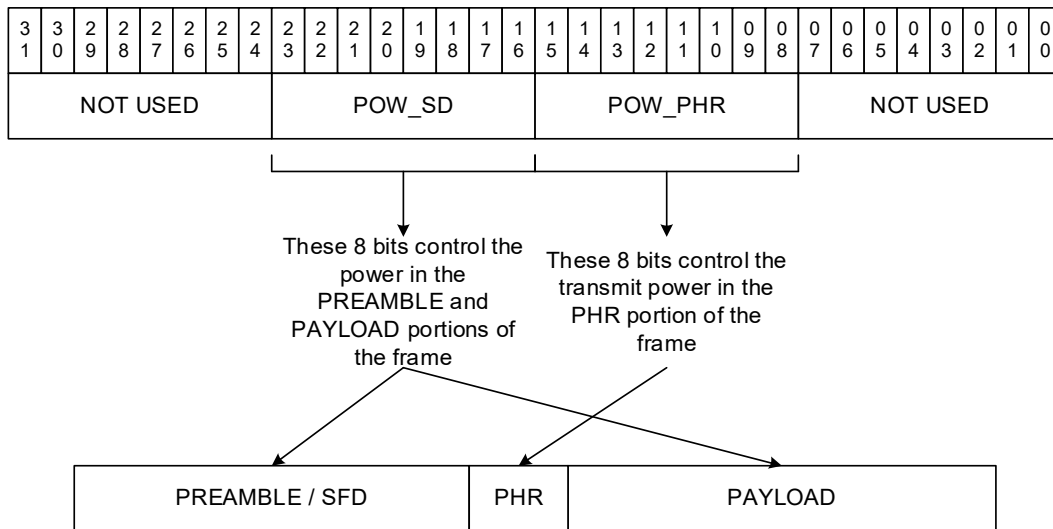

Figure 11: Transmit power control register in manual mode of operation

If the frame is longer than one millisecond, the transmit power in both portions of the message should be the same.

If the frame duration is less than one millisecond then you may increase the power in the preamble and payload portions of the frame as per section 3.2 above. Figure 12 illustrates an example of this -

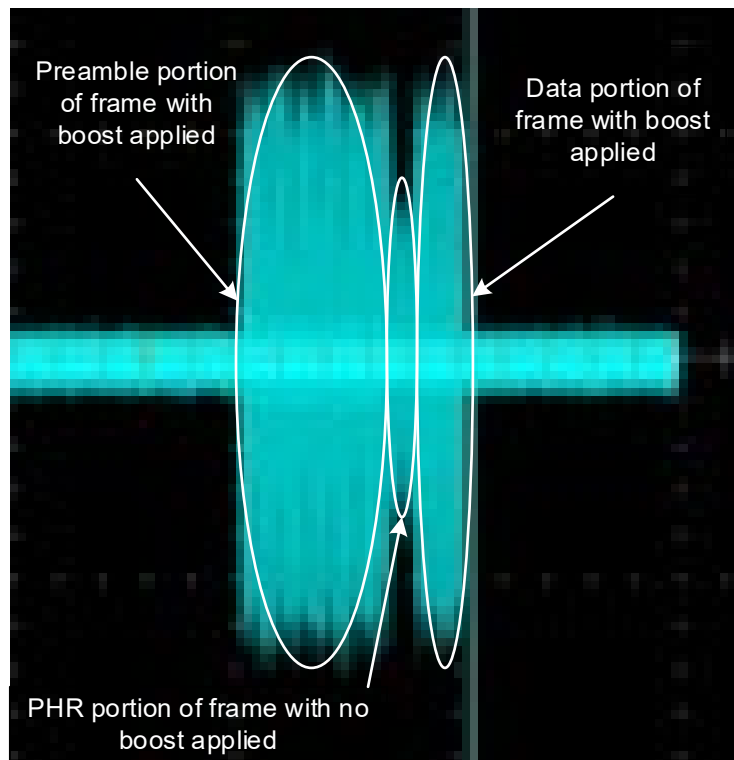

Figure 12: Time domain plot of frame showing increased power in preamble and payload portions of the frame

We discuss how to calibrate this in the next section.

5.3 Calibrating transmit power in MANUAL mode

5.3.1 Introduction

In order to calibrate transmit power in manual mode there are a number of cases to consider. The decision tree in Figure 13 below will help guide you. The following sections consider each case in more detail.

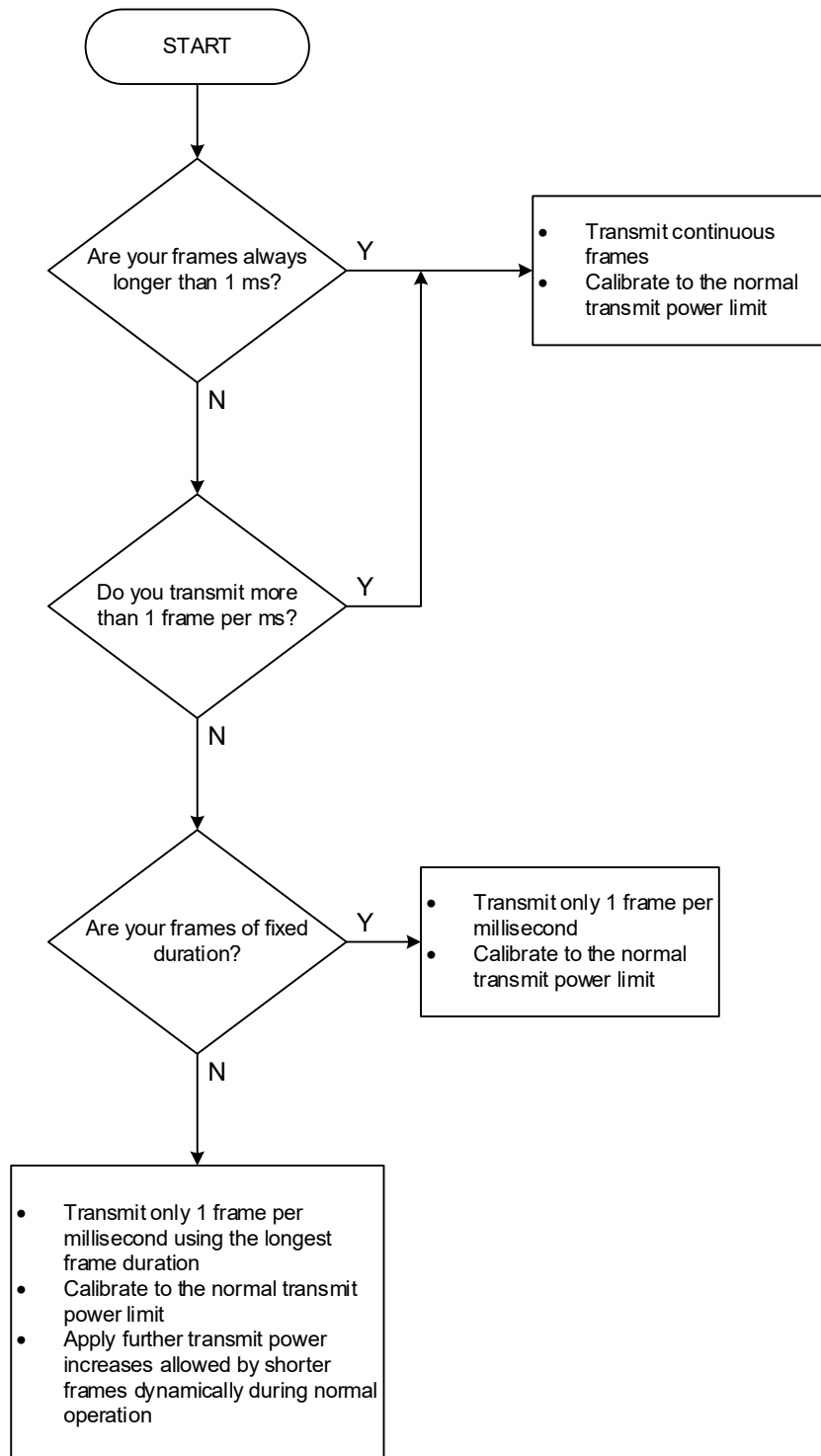

Figure 13: Decision tree for transmit power calibration in MANUAL mode

5.3.2 Frames always longer than one millisecond

If the frames in your system are always longer than one millisecond (for example because you are using a 1024 symbol or longer preamble length or a data rate other than 6.8 Mb/s) then you cannot benefit from any boost in transmit power.

In this case, you should configure your unit under test to transmit continuous frames. It is not necessary to do this but it does speed up the measurement time on the spectrum analyser.

You should then measure the mean power as specified in section 2.4 and adjust the values in the POW_SD and POW_SHR fields (keeping the values the same) until the mean transmit power approaches the -41.3 dBm / MHz limit.

5.3.3 More than 1 frame transmitted per millisecond

If your system always transmits more than one frame per millisecond, then you cannot benefit from any boost in transmit power.

In this case, you should configure your unit under test to transmit continuous frames. It is not necessary to do this but it does speed up the measurement time on the spectrum analyser.

You should then measure the mean power as specified in section 2.4 and adjust the values in the POW_SD and POW_SHR fields (keeping the values the same) until the mean transmit power approaches the -41.3 dBm / MHz limit.

5.3.4 Only one frame transmitted per millisecond and frame duration constant

If your system transmits only one constant-duration frame per millisecond (or at longer intervals) then you can benefit from boosting the transmit power.

You should proceed as in section 7.

5.3.5 Only one frame transmitted per millisecond but with variable duration

Likewise, if your system transmits only one frame per millisecond but those frames have variable length (all less than one millisecond) then you can benefit from boosting the transmit power.

You should proceed as in section 7.

5.4 Enabling MANUAL mode

To enable MANUAL mode, you need to do two things: -

1. Program the power levels for the two portions of the frame as described above.
2. Enable MANUAL mode by **setting** the DIS_STXP bit (bit 18) in the SYSTEM CONFIGURATION REGISTER located at address 0x04 offset 0.

CAUTION: If you wish to use SMARTTX POWER mode rather than MANUAL mode then you will need to clear the DIS_STXP bit.

REG:04:00 – SYS_CFG – System Configuration bit map																															
31	30	29	28	27	26	25	24	23	22	21	20	19	18	17	16	15	14	13	12	11	10	9	8	7	6	5	4	3	2	1	0
AACKPEND	AUTOACK	RXAUTR	RXWTOE	-	-	-	-	-	RXM110K	-	-	-	DIS_STXP	PHR_MODE	FCS_INIT2F	DIS_RSDE	DIS_PHE	DIS_DRXB	DIS_FCE	SPI_EDGE	HIRQ_POL	FFA5	FFA4	FFAR	FFAM	FFAA	FFAD	FFAB	FFBC	FFEN	
0	0	0	0	0	0	0	0	0	0	0	0	0	0	0	0	0	0	0	1	0	0	1	0	0	0	0	0	0	0	0	0

6 SMARTTX POWER MODE

6.1 Introduction

In MANUAL mode the user must program the desired transmit power setting for each frame. As frames become progressively shorter, greater amounts of boost may be applied to the preamble and data portions of the frame. To remove the necessity for the user to continually modify the transmit power setting based on the frame duration in MANUAL mode, SMARTTX POWER mode may be used instead.

In SMARTTX POWER mode the DW1000 automatically selects between 4 different preprogrammed power settings based on the duration of the frame. The DW1000 divides frame durations into four “bins”. For each frame to be transmitted, the DW1000 calculates its duration, determines into which “bin” it falls, and then selects the transmit power value preprogrammed for that “bin”.

6.2 Adjusting transmit power in SMARTTX POWER mode

The four ranges of frame duration are as shown in Figure 14 below.

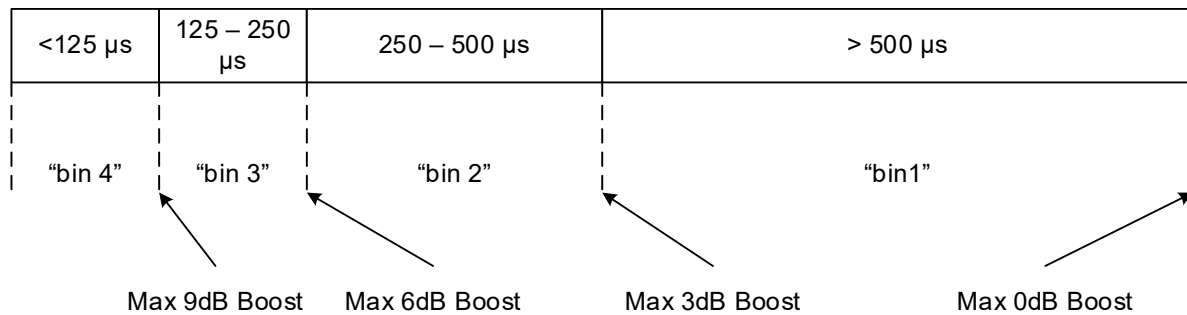

Figure 14: The four frame-duration “bins”

The actual values of transmit power used for each of these four options can be configured by the user in the transmit power control register 0x1E as illustrated in Figure 15 to Figure 18 below.

When SMARTTX POWER mode is enabled control register 0x1E looks as follows: -

3	3	2	2	2	2	2	2	2	2	2	2	1	1	1	1	1	1	1	1	1	0	0	0	0	0	0	0	0	0	0	0	0
1	0	9	8	7	6	5	4	3	2	1	0	9	8	7	6	5	4	3	2	1	0	9	8	7	6	5	4	3	2	1	0	
BOOSTP125								BOOSTP250								BOOSTP500								BOOSTNORM								

The DW1000 uses the BOOSTNORM byte to set the transmit power in the PHR portion of the frame irrespective of the frame duration. It then uses the frame duration to select which of the 4 bytes to use to set the transmit power in the PREAMBLE and PAYLOAD portions of the frame.

Figure 15 to Figure 18 below illustrate the four cases.

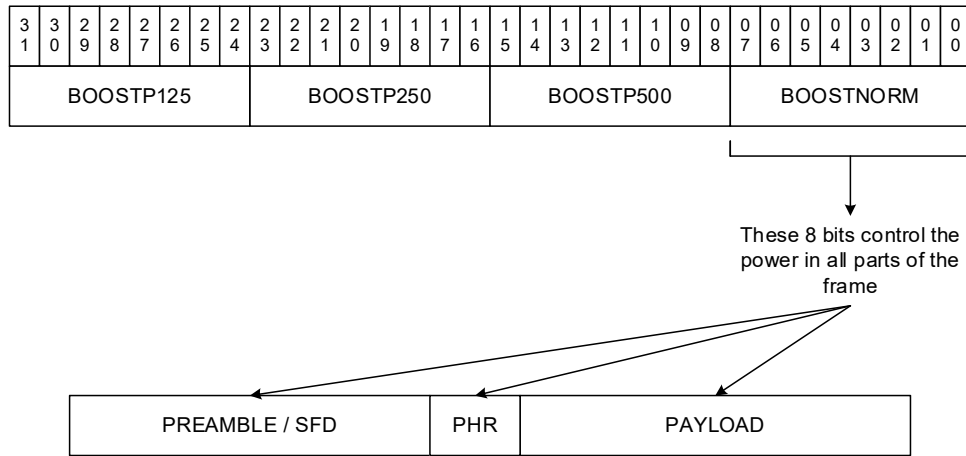

Figure 15: Transmit power control register for frames with duration > 500µs

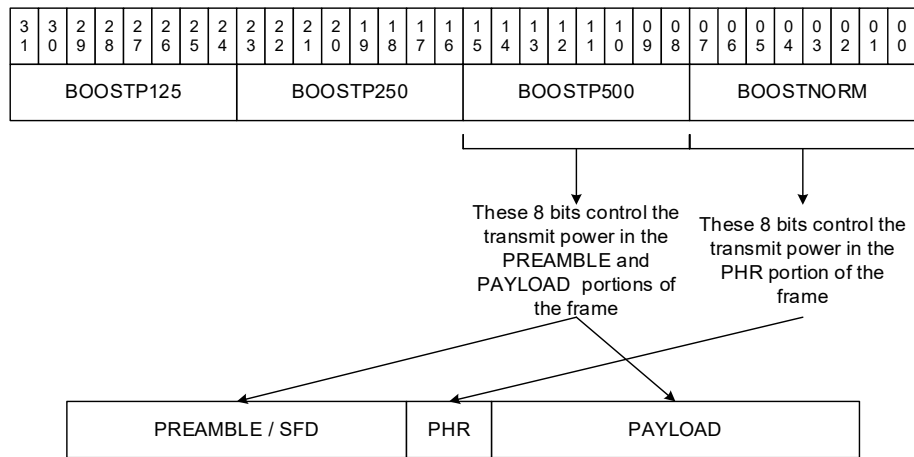

Figure 16: Transmit power control register for frames with duration between 250 µs & 500 µs

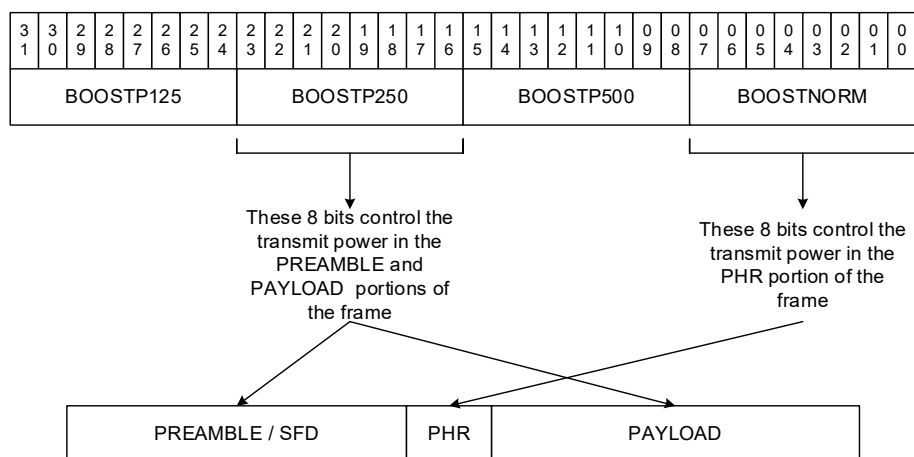

Figure 17: Transmit power control register for frames with duration between 125 µs & 250 µs

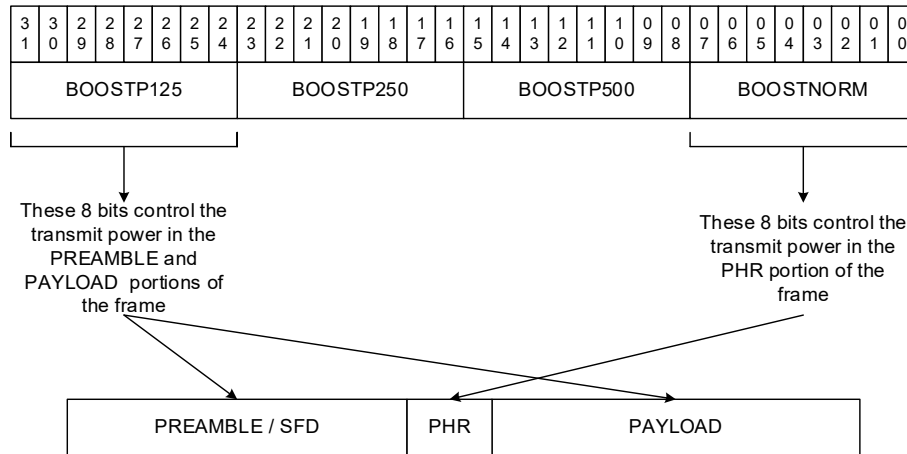

Figure 18: Transmit power control register for frames with duration less than 125 μ s

6.3 Calibrating transmit power in SMARTTX POWER mode

Calibrating transmit power in SMARTTX POWER mode means performing four separate calibrations – one for each of the four frame duration “bins”.

You should do this as outlined in Section 7.

6.4 Enabling SMARTTX POWER mode

To enable SMARTTX POWER, you need to do two things: -

1. Program the power levels for the four different frame durations as described above.
2. Enable SMARTTX POWER by clearing the DIS_STXP bit (bit 18) in the SYSTEM CONFIGURATION REGISTER located at address 0x04 offset 0.

CAUTION: If you wish to use MANUAL mode then you will need to set the DIS_STXP bit

REG:04:00 – SYS_CFG – System Configuration bit map																															
31	30	29	28	27	26	25	24	23	22	21	20	19	18	17	16	15	14	13	12	11	10	9	8	7	6	5	4	3	2	1	0
AACKPEND	AUTOACK	RXAUTR	RXWTOE	-	-	-	-	-	RXM110K	-	-	-	DIS_STXP	PHR_MODE	FCS_INIT2F	DIS_RSDE	DIS_PHE	DIS_DRXB	DIS_FCE	SPI_EDGE	HIRQ_POL	FFA5	FFA4	FFAR	FFAM	FFAA	FFAD	FFAB	FFBC	FFEN	
0	0	0	0	0	0	0	0	0	0	0	0	0	0	0	0	0	0	0	1	0	0	1	0	0	0	0	0	0	0	0	0

7 CALIBRATING A DW1000 TRANSMITTER WITH BOOST

To calibrate a DW1000-based transmitter that applies a transmit power boost, in either MANUAL or SMARTTX POWER modes you should proceed as follows: -

1. The first thing to do is to establish the power setting for the PHR field. To do this, you should configure your unit under test to transmit continuous frames. You should then measure the mean power as specified in section 2.4: -
 - a. In MANUAL MODE you should adjust the values of the POW_SD and POW_PHR fields (keeping the values the same) until the mean transmit power approaches the -41.3 dBm / MHz limit. You now have the **correctly calibrated value for the POW_PHR field**.
 - b. In SMARTTX POWER mode you should adjust the value in the BOOST_NORM field until the mean transmit power approaches the -41.3 dBm / MHz limit. You now have the **correctly calibrated value for the BOOST_NORM field**.

Figure 19 shows a spectrum analyser example for 6.8 Mb/s data rate frame with a PRF of 16 MHz.

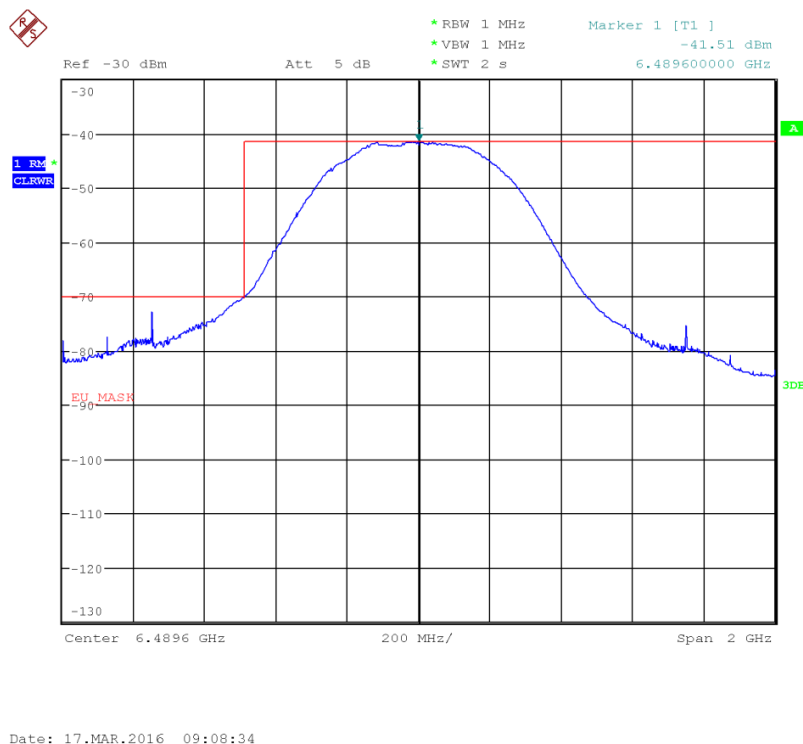

Figure 19: Spectrum of correctly calibrated transmitter at data rate of 6.8 Mb/s with PRF16 and no boost applied

2. Determine the approximate amount of boost to apply to the preamble and payload portions of the frame using the formula in section 3.2 based on the frame duration. Translate this into a register value using the description in section 4.4 above.
 - a. In MANUAL mode, leave the value in the POW_PHR field in register 0x1E as per Step 1(a). Program the power boost value from step 2 into the POW_SD field.
 - b. In SMARTTX POWER mode, leave the value in the BOOST_NORM field in register 0x1E as per Step 1(b). Program the power boost value from step 2 into the appropriate BOOSTPxx field depending on the frame duration.
3. Set up a test mode to transmit one frame every millisecond by writing 0x0001E800 into register 0xA. An example of this is shown below:

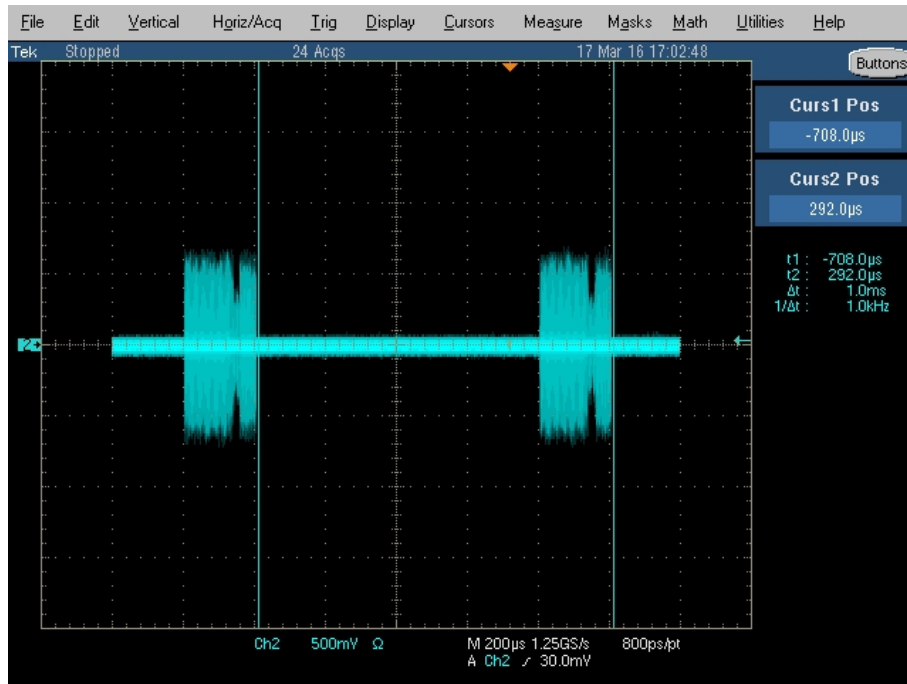

Figure 20: Transmitting one frame per millisecond

4. Measure the transmit power on the spectrum analyser and adjust as follows: -
 - a. In MANUAL mode adjust the value of the POW_SD field until the mean transmit power approaches the -41.3 dBm / MHz limit.
 - b. In SMARTTX POWER mode adjust the value of the appropriate BOOSTPxx field until the mean transmit power approaches the -41.3 dBm / MHz limit.

Figure 21 shows a spectrum analyser example for 6.8 Mb/s PRF16 with 7 dB boost applied.

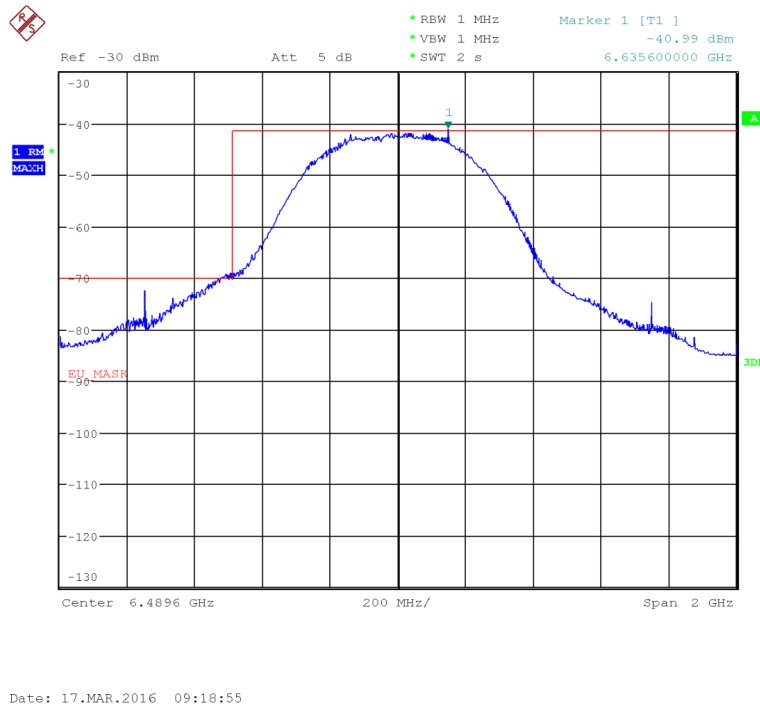

Figure 21: Spectrum of correctly calibrated transmitter at 6.8 Mb/s data rate with PRF16 and 7

dB boost applied

5. In both MANUAL and SMARTTX POWER modes the spectrum should look the same as at step 1 above.
6. In SMARTTX POWER mode you should repeat steps 2, 3 & 4 for the other BOOSTPxx fields using frames of the appropriate duration.

8 MANAGING TRANSMIT POWER DURING NORMAL OPERATION

8.1 Introduction

The output of the DW1000 transmitter varies with temperature and voltage to a greater or lesser extent depending on the selected RF channel. In order to ensure maximum link budget over the entire operating temperature and voltage range it is necessary to adjust the transmit power as temperature and voltage change to maintain a constant output power.

8.2 Variation of transmit power with temperature and voltage

The variation of transmit power is described in [1] and illustrated in Figure 22 below

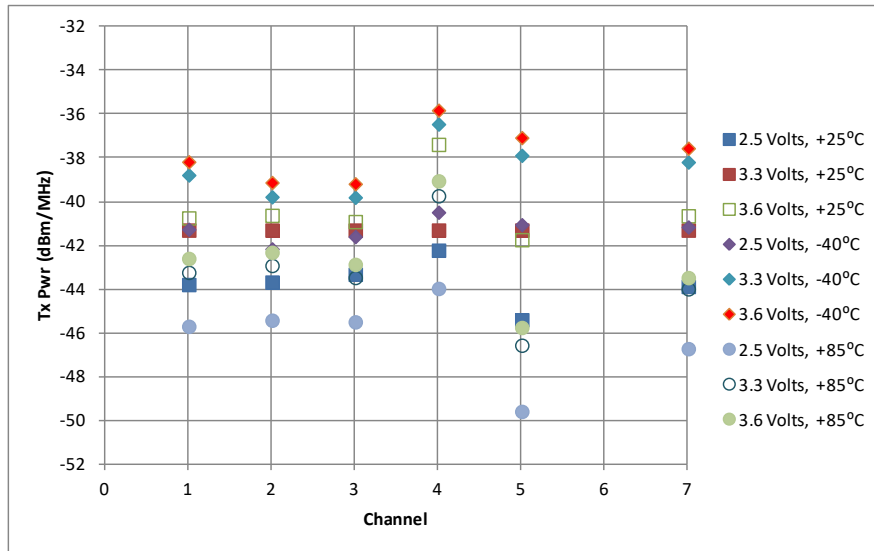

Figure 22: Variation of transmit power over voltage and temperature

This shows for example, that a transmitter configured for channel 2 and correctly calibrated at room temperature and nominal voltage will see its output power drop to -45.5 dB at low voltage and high temperature and rise to -39 dB at high voltage and low temperature. This 6.5 dB spread is very significant: -

- In the -39 dB case, the product will be in breach of regulatory limits
- In the -45.5 dB case the link budget will be impacted

Spreads on other operating channels are different with channel 5 showing the widest spread.

8.3 Maintaining transmit power over temperature and voltage

8.3.1 Is it necessary?

Whether or not you need to deal with this variation of transmit power depends very much on your intended use case. Table 1 below gives two typical examples. Clearly, there are many more and you need to carefully consider your application to decide if and how often you need to adjust the transmit power.

Table 1: Typical use case examples

Use case	Operating Temperature	Operating Voltage	Recommendation
Product intended for indoor use only	Room temperature only	Maintained at 3.3 V	No need to adjust for variation in transmit output power. Calibration at nominal values is sufficient
Product intended for both indoor and outdoor use	Full range	Full range	Transmit power should be dynamically adjusted

8.3.2 How do I implement it?

The DW1000 contains an on-board A/D converter that measures temperature and voltage. Once these variables are known and the variation of transmit power with those variables is known then implementing a control mechanism for transmit power is relatively straightforward.

Transmit power reduces as a function of increasing temperature and increases with increasing voltage. Knowing: -

- these rates of change
- the temperature and voltage at which the product was initially calibrated to the -41.3 dBm / MHz limit
- the present temperature and voltage

then the change required to return the transmit power value to the correct level can be calculated and programmed into the transmit power control register.

The rates of change vary by channel approximately as follows: -

Table 2: Approximate rates of change of Tx power with temperature and voltage

Channel	Tx power increase with voltage		Tx power reduction with Temperature	
	Value	Units	Value	Units
2	+2.73	dB / V	-0.035	dB / deg C
5	+3.34	dB / V	-0.065	dB / deg C

The basic scheme is that the software controlling the DW1000 performs the following sequence: -

1. Measure the chip temperature using the on-chip A/D converter as described in [2].
2. Measure the supply voltage using the on-chip A/D converter as described in [2].
3. Note the differences between these new values and the previously measured values (or the nominal calibration temperature / voltage as stored in the on-chip OTP during production test if this is a cold start).
4. Use these differences in a calculation to determine the correct values for the transmit power control register.

The software can calculate the total change in transmit power as follows: -

$$\Delta P_{TXTotal} = +\Delta P_{TXVoltage} + \Delta P_{TXTemp}$$

Where: -

$\Delta P_{TXTotal}$: total change in Tx power due to change in both temperature and voltage
 $\Delta P_{TXVoltage}$: is the change in transmit power due to a change in voltage; and
 ΔP_{TXTemp} : is the change in transmit power due to a change in temperature

You can calculate these quantities as follows: -

$$\begin{aligned} \Delta P_{TXVoltage} &= +2.73*(V_{now} - V_{previous}) \text{ (for channel 2. Use +3.34 for channel 5)} \\ \Delta P_{TXTemp} &= -0.035*(t_{now} - t_{previous}) \text{ (for channel 2. Use -0.065 for channel 5)} \end{aligned}$$

Where: -

V_{now} : is the latest voltage measurement
 $V_{previous}$: is the previously measured voltage
 t_{now} : is latest temperature measurement
 $t_{previous}$: is the previously measured temperature.

If $\Delta P_{TXTotal} > 0.5$ dB then you should adjust the output power in the appropriate direction by modifying the contents of register 0x1E depending on your mode of operation.

The frequency at which you do this depends on your use case. For example, in a system where: -

- a) a unit transmits only at infrequent intervals (a low-update rate tag in a real time location system for instance),
- b) the physical environment of the transmitter could have changed since the previous transmission

then before each transmission or group of transmissions the controlling software should perform steps 1 to 3 of the above sequence.

If the values have not changed since the previous measurement then no change to the transmit power is required; if they have changed then a new value for the transmit power control register can be determined and programmed into the DW1000 prior to transmission.

In most designs it is probable that the voltage will be well controlled (via regulators or DC/DC convertors) and will not vary significantly over time therefore the variable of most concern is likely to be temperature.

In order to facilitate the compensation of transmit power, an API function has been added to the DW1000 API (namely `dwt_calcpowertempadj()`) to calculate this adjustment to register 0x1E based off the temperature change. Full details of how this function works are included in [7].

Figure 23 gives a simple flowchart as guidance.

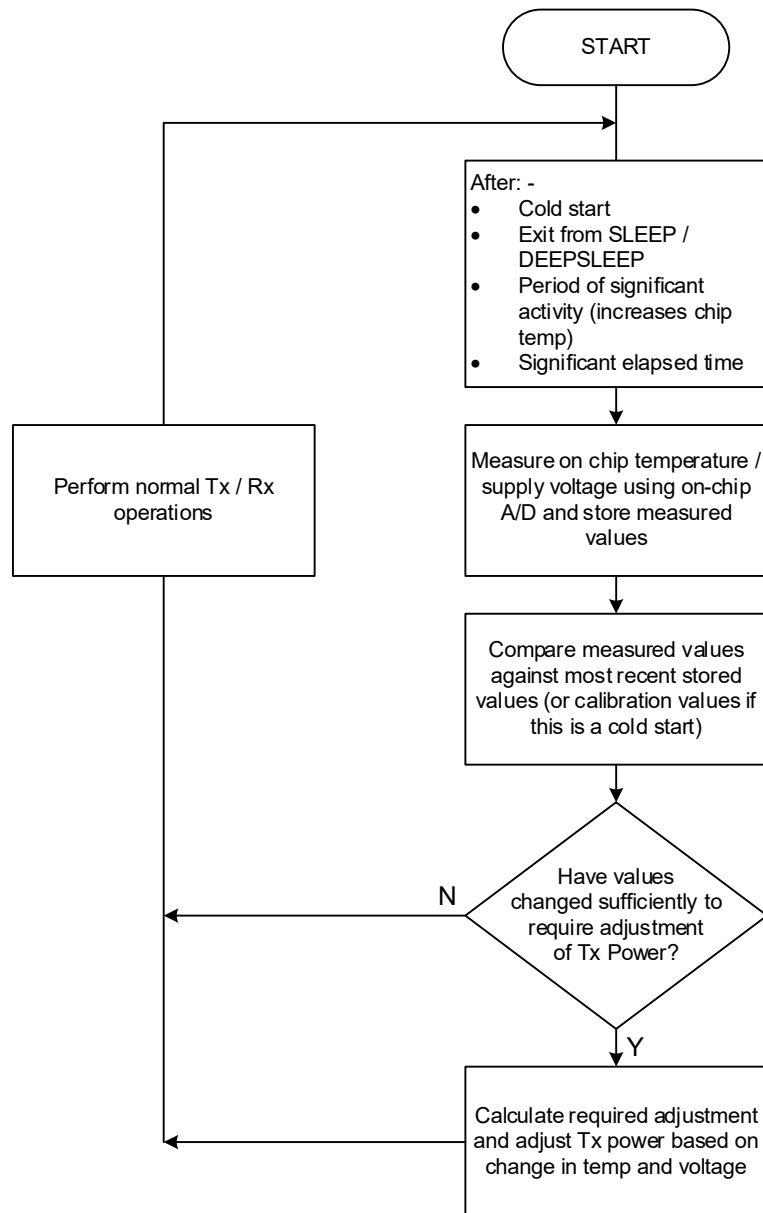

Figure 23: Transmit power compensation scheme over temperature & voltage

9 REFERENCES

9.1 Listing

References are made to the following documents in the course of this document:

Table 3: Table of References

Ref	Author	Version	Title
[1]	Decawave	Current	DW1000 Data Sheet
[2]	Decawave	Current	DW1000 User Manual
[3]	Decawave	Current	APR001 UWB worldwide regulations summary
[4]	Decawave	Current	APR002 Certification Guide USA
[5]	Decawave	Current	APR003 Certification Guide Europe
[6]	Decawave	Current	APS012 Production test
[7]	Decawave	Current	APS023 Part 2 TX Bandwidth and Power Compensation

10 DOCUMENT HISTORY

10.1 Revision History

Table 4: Document History

Revision	Date	Description
1.0	30 th June 2016	Initial release
1.1	22 nd November 2016	Added reference to TX bandwidth/power compensation application note
1.2	31 st July 2018	Scheduled Update
1.3	10 th July 2019	Updated figure 10 to reflect coarse gain (DA) steps of 2.5 dB

11 MAJOR CHANGES

Revision 1.0

Page	Change Description
All	Initial release

Revision 1.1

Page	Change Description
1	Changed name of app note to reflect relationship to APS023 part 2 Changed revision to 1.1
24	Changed value for rate of change of power over temperature to reflect updated experimental values
25	Included reference to new app note containing details of bandwidth/power compensation over temperature
27	Added new app note as reference listing

Revision 1.2

Page	Change Description
All	Update of revision number from 1.1 to 1.2
All	Update of company logo

REVISION 1.3

Page	Change Description
All	Updated figure 10 to reflect coarse gain (DA) steps of 2.5 dB

12 FURTHER INFORMATION

Decawave develops semiconductors solutions, software, modules, reference designs - that enable real-time, ultra-accurate, ultra-reliable local area micro-location services. Decawave's technology enables an entirely new class of easy to implement, highly secure, intelligent location functionality and services for IoT and smart consumer products and applications.

For further information on this or any other Decawave product, please refer to our website www.decawave.com.

13 APPENDIX 1: IS IT NECESSARY TO MEASURE PEAK POWER IN PRODUCTION?

As mentioned previously in this note, if transmit power boost is being applied then the power level of the PHR is set first. Only after the power level of the PHR has been set is the power level of the preamble and data portions of the frame increased.

The reason for doing this is that the modulation scheme in the PHR has a higher peak to average ratio than the modulation scheme for the other parts of the frame

Normally it is not necessary to measure peak power in production testing. This is because once the PHR limit is calibrated to just below the -41.3 dBm / MHz limit, the peak power will pass with a deterministic margin.

As an example, the calculated peak power margin for a frame using a 6.8 Mb/s data rate, with 16 MHz PRF, with a duration of less than 200 μ s and with boost applied is 3 dB. A measured plot for this example is shown below which gives exactly the margin predicted (the peak power limit is 0 dBm)

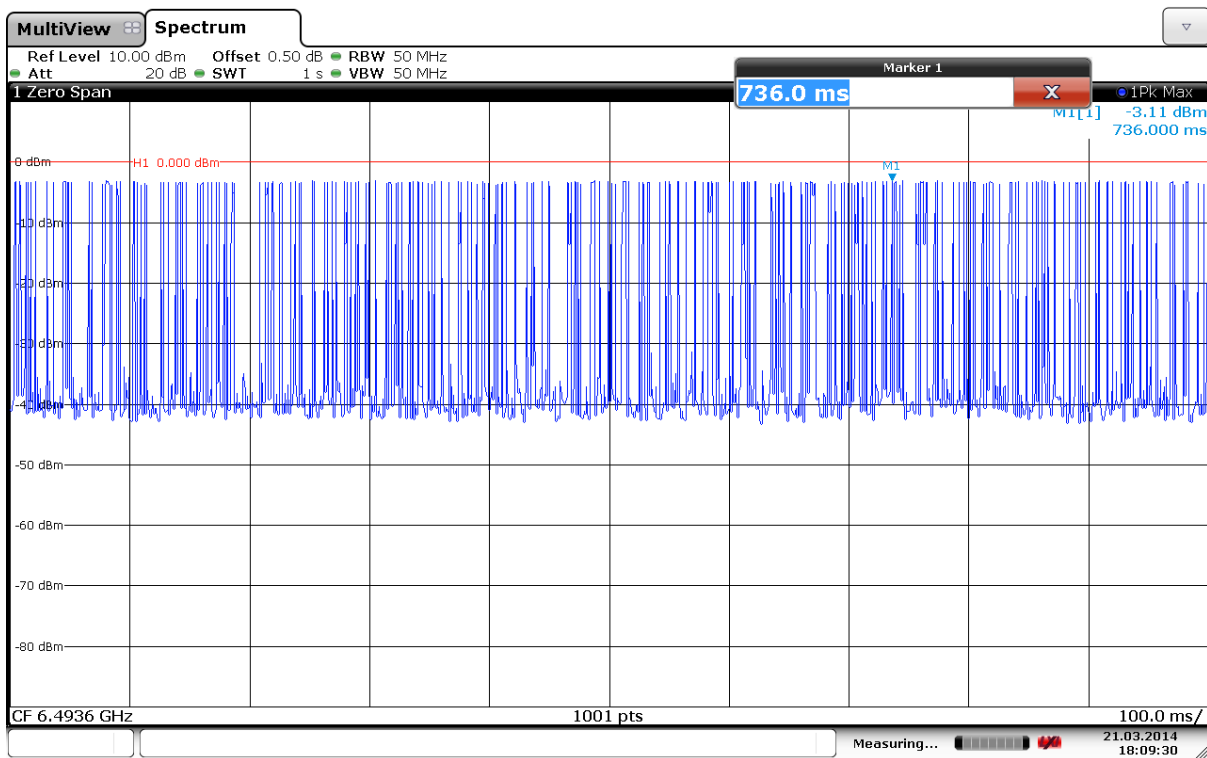

Date: 21.MAR.2014 18:09:30

Figure 24: Example of peak power margin when PHR mean limit set to -41.3 dBm / MHz